

- (A) Zastavbovy rozmer / Baumaße / In-built dimension  
 (B) Litinový odvod kouře / Cast iron spigot / Der gusseiserne Rauchabgang  
 (C) Centralni prived vzduchu / Central air inlet / Zentralluftzufuhr  
 (D) Primarni a sekundarni vzduch / Primary and secondary air / Primärluft und Sekundärluft  
 (L) Volna plocha proskleni / Free glass area / Freie Glassichtfläche

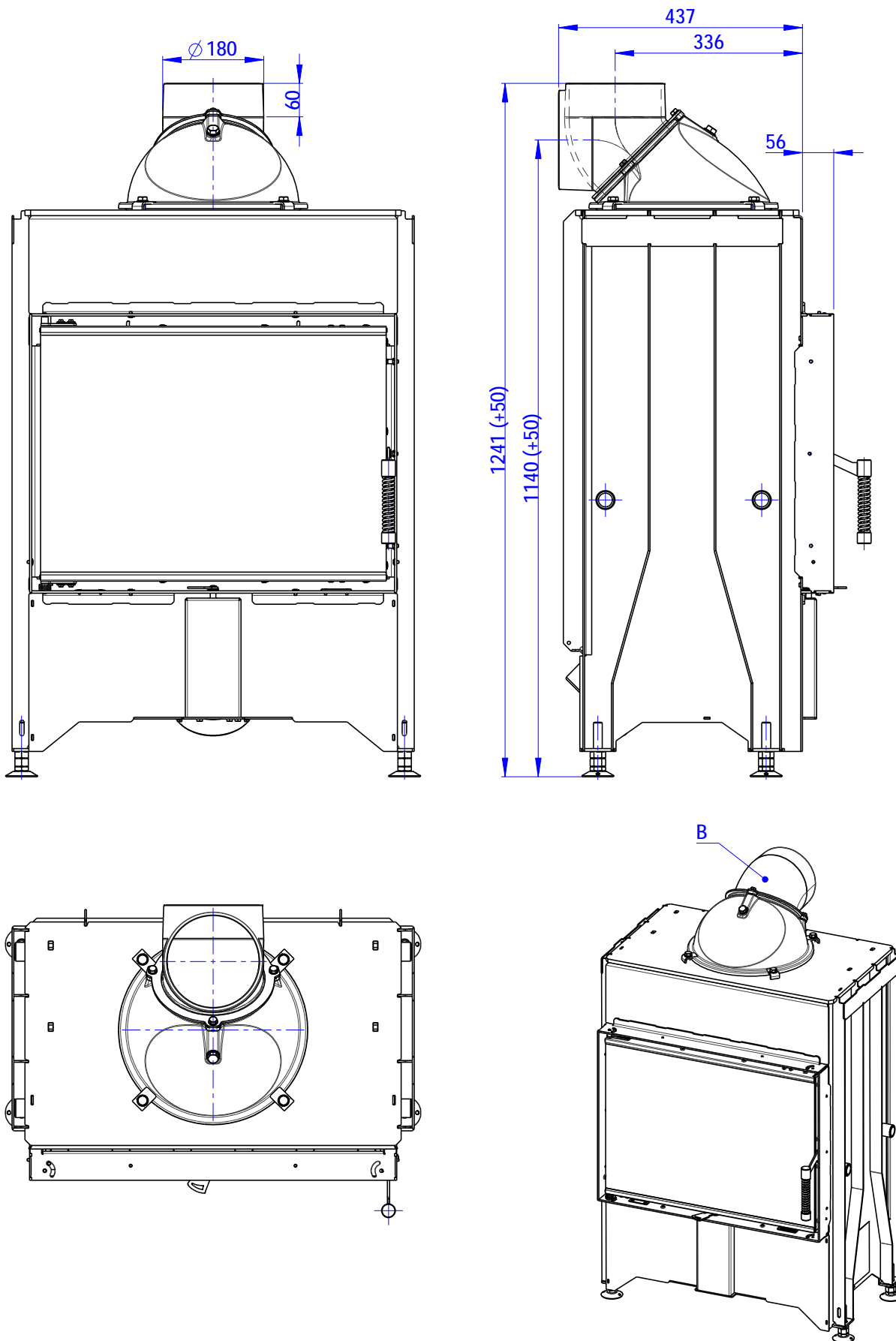

- (A) Zastavbovy rozmer / Baumaße / In-built dimension
- (B) Litinový odvod kouře / Cast iron spigot / Der gusseiserne Rauchabgang
- (C) Centralni privod vzduchu / Central air inlet / Zentralluftzufuhr
- (D) Primarni a sekundarni vzduch / Primary and secondary air / Primärluft und Sekundärluft
- (L) Volna plocha proskleni / Free glass area / Freie Glassichtfläche

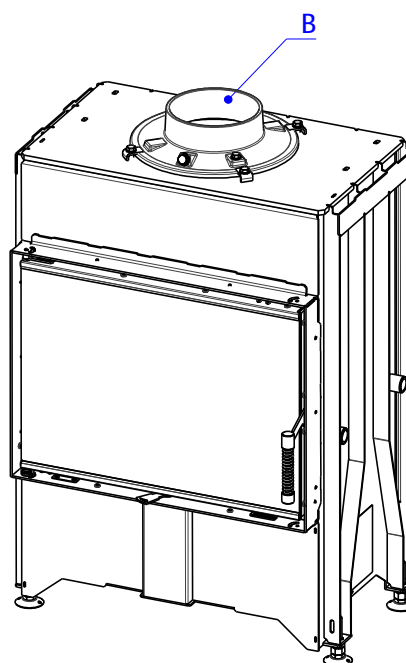
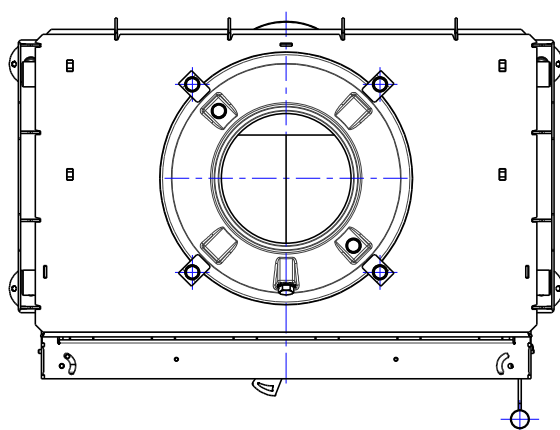
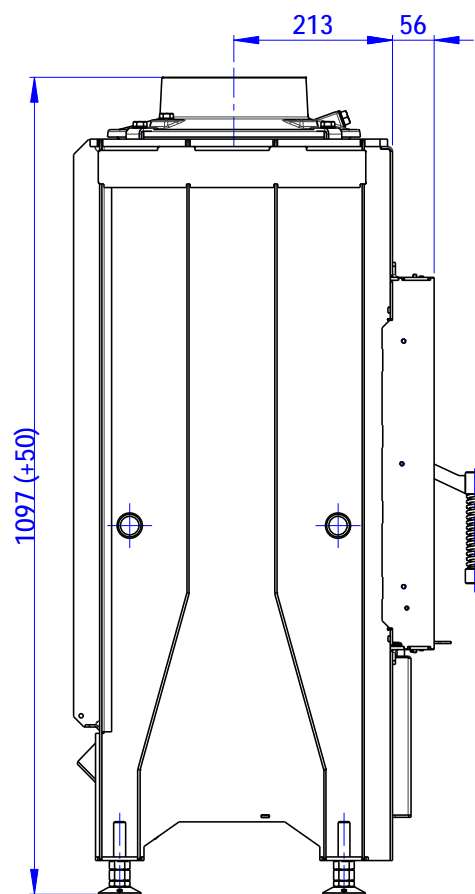
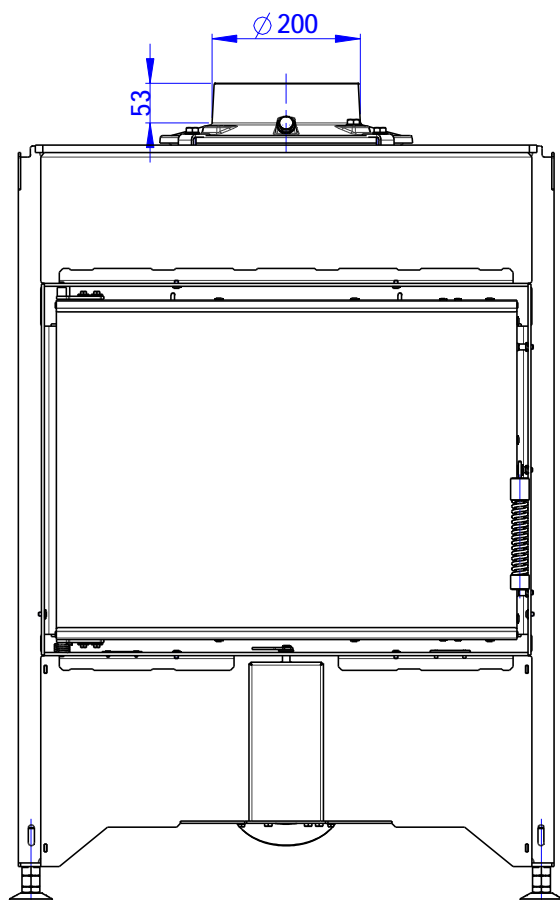

- (A) Zastavbovy rozmer / Baumaße / In-built dimension
- (B) Litinový odvod kouře / Cast iron spigot / Der gusseiserne Rauchabgang
- (C) Centralni privod vzduchu / Central air inlet / Zentralluftzufuhr
- (D) Primarni a sekundarni vzduch / Primary and secondary air / Primärluft und Sekundärluft
- (L) Volna plocha proskleni / Free glass area / Freie Glassichtfläche

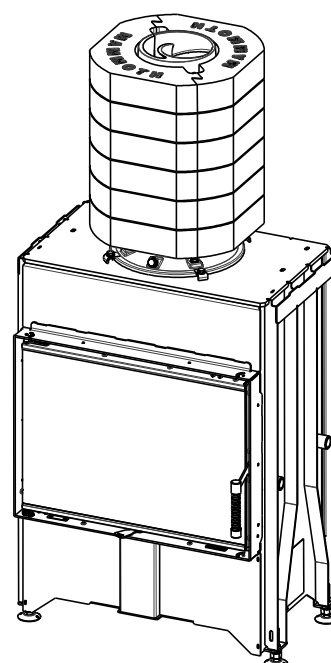
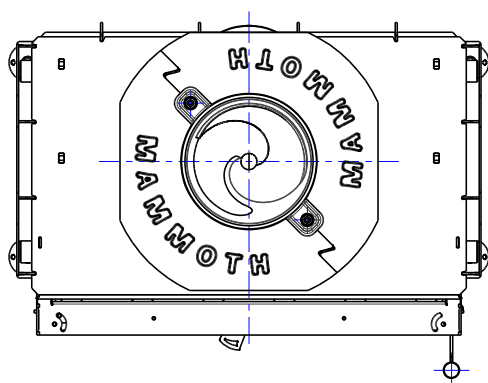
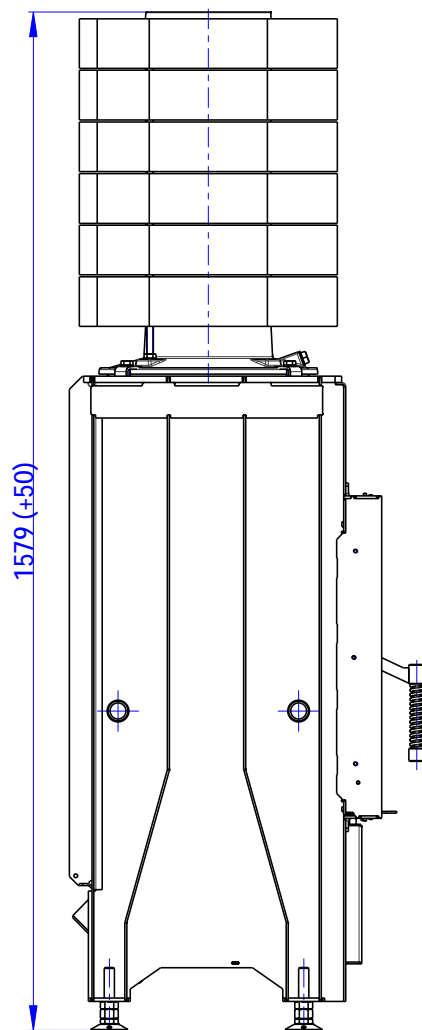
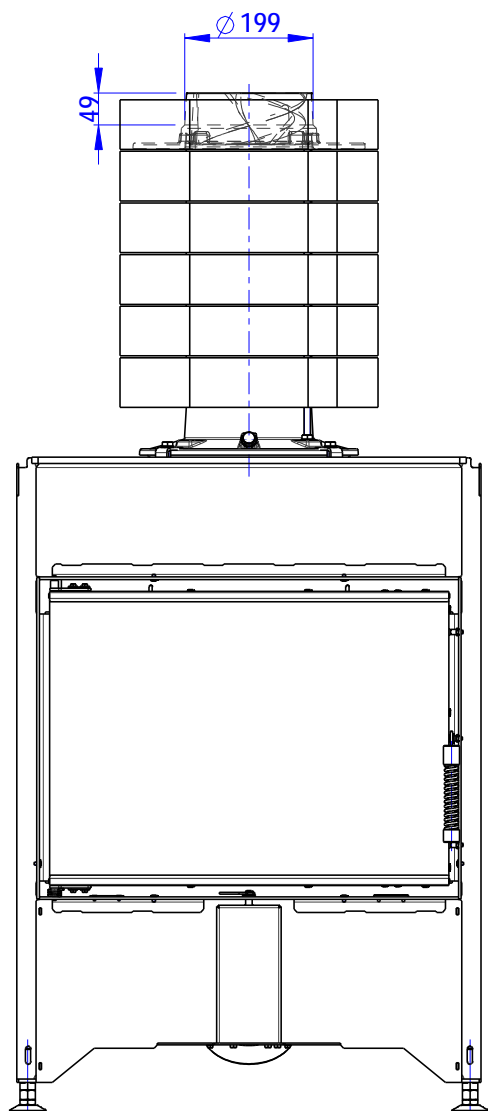

- (A) Zastavbovy rozmer / Baumaße / In-built dimension
- (B) Litinový odvod kouře / Cast iron spigot / Der gusseiserne Rauchabgang
- (C) Centralni privod vzduchu / Central air inlet / Zentralluftzufuhr
- (D) Primarni a sekundarni vzduch / Primary and secondary air / Primärluft und Sekundärluft
- (L) Volna plocha proskleni / Free glass area / Freie Glassichtfläche

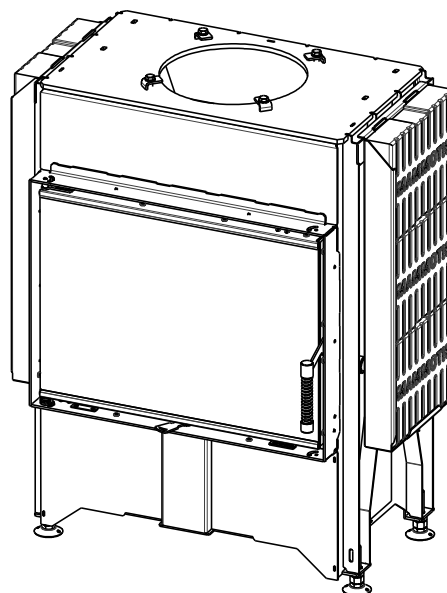
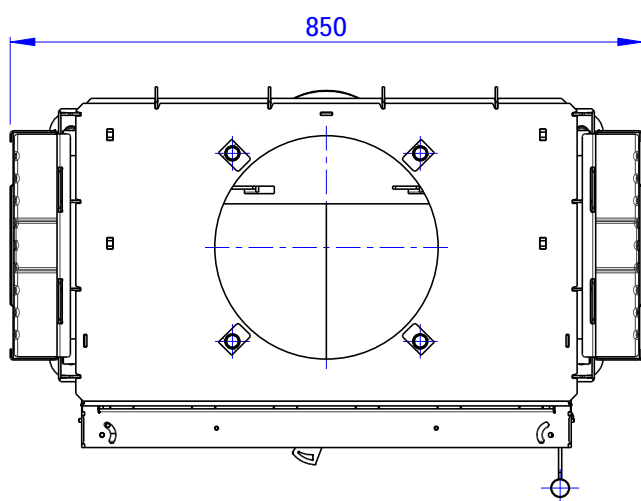
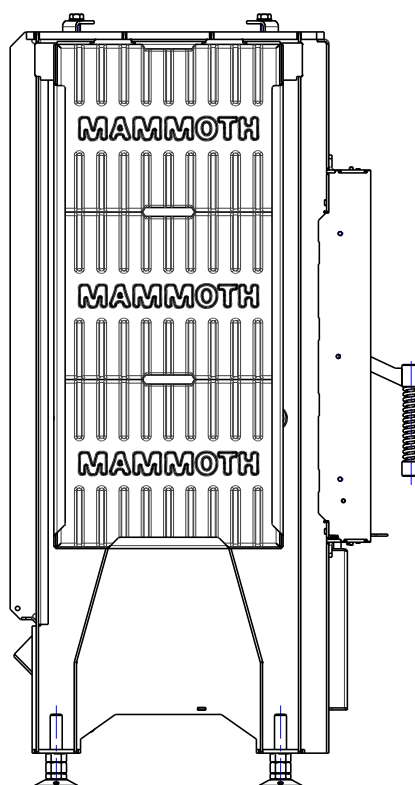
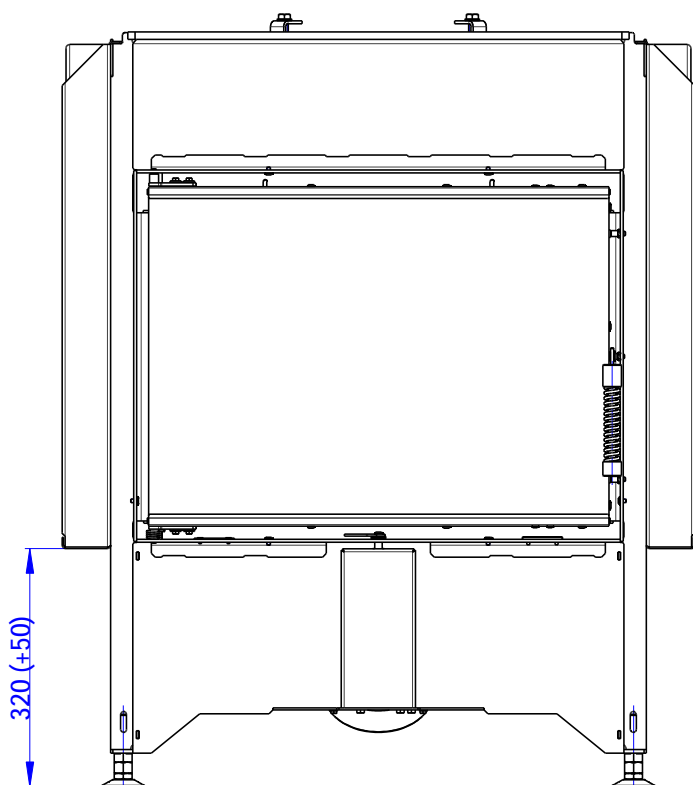

- (A) Zastavbovy rozmer / Baumaße / In-built dimension
- (B) Litinový odvod kouře / Cast iron spigot / Der gusseiserne Rauchabgang
- (C) Centralni privod vzduchu / Central air inlet / Zentralluftzufuhr
- (D) Primarni a sekundarni vzduch / Primary and secondary air / Primärluft und Sekundärluft
- (L) Volna plocha proskleni / Free glass area / Freie Glassichtfläche

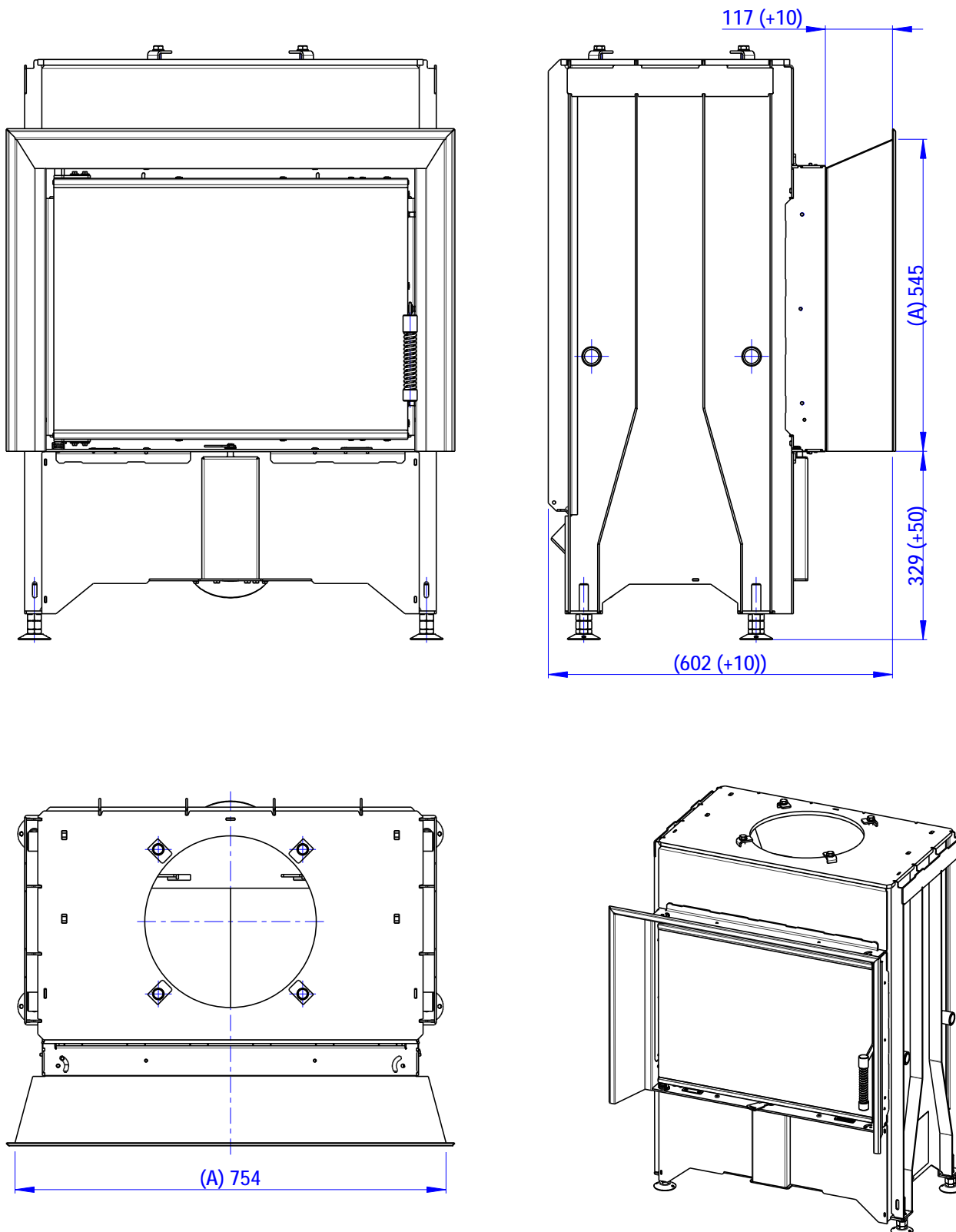

- (A) Zastavbovy rozmer / Baumaße / In-built dimension  
 (B) Litinový odvod kouře / Cast iron spigot / Der gusseiserne Rauchabgang  
 (C) Centralní privod vzduchu / Central air inlet / Zentralluftzufuhr  
 (D) Primární a sekundární vzduch / Primary and secondary air / Primärluft und Sekundärluft  
 (L) Volná plocha prosklení / Free glass area / Freie Glassichtfläche

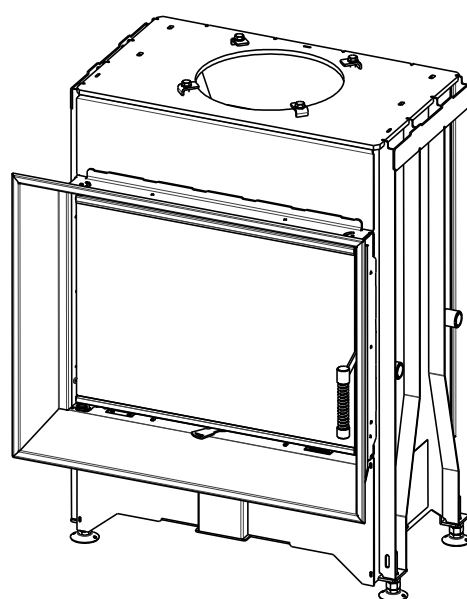
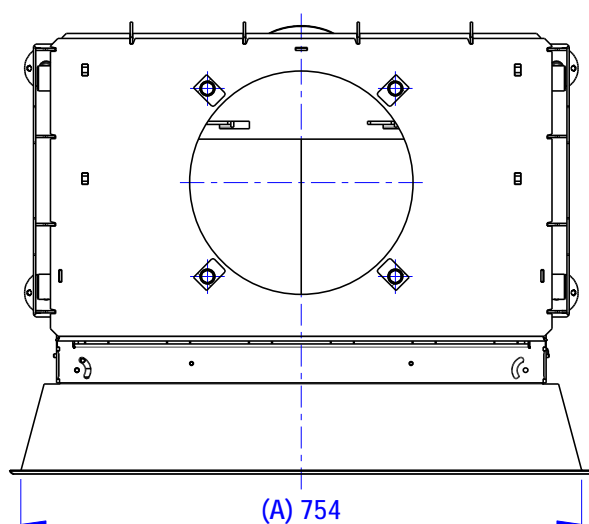
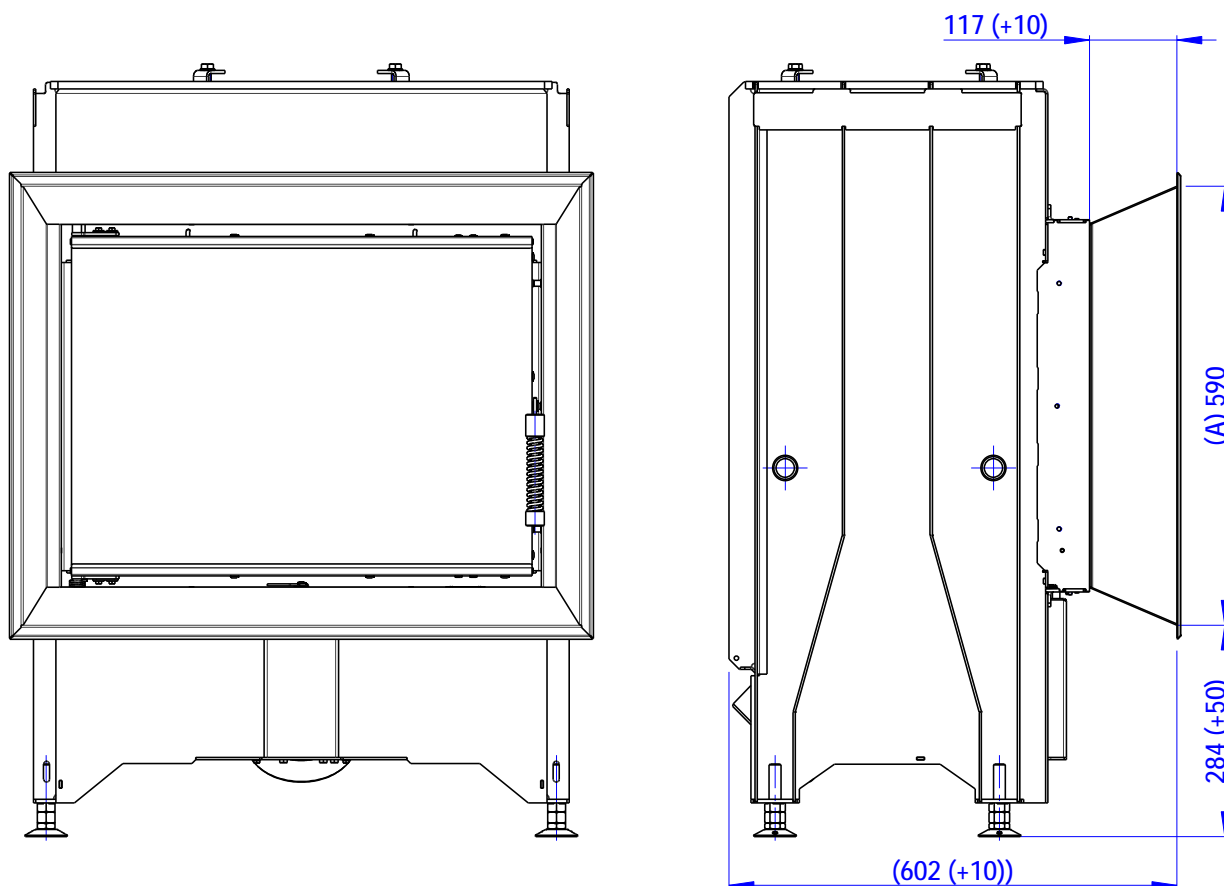

- (A) Zastavbovy rozmer / Baumaße / In-built dimension
- (B) Litinový odvod kouře / Cast iron spigot / Der gusseiserne Rauchabgang
- (C) Centralní privod vzduchu / Central air inlet / Zentralluftzufuhr
- (D) Primární a sekundární vzduch / Primary and secondary air / Primärluft und Sekundärluft
- (L) Volná plocha prosklení / Free glass area / Freie Glassichtfläche

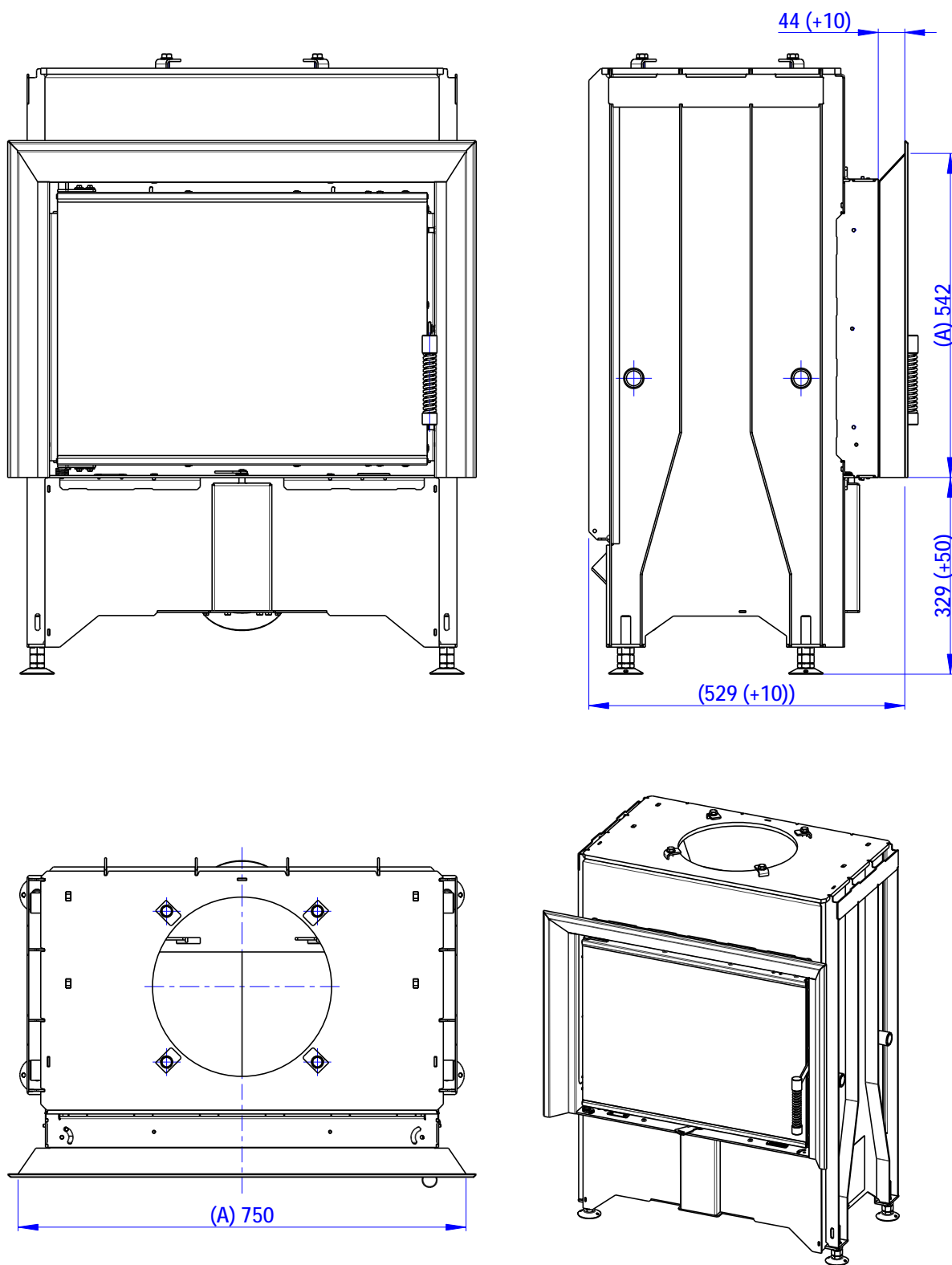

- (A) Zastavbovy rozmer / Baumaße / In-built dimension
- (B) Litinový odvod kouře / Cast iron spigot / Der gusseiserne Rauchabgang
- (C) Centralni privod vzduchu / Central air inlet / Zentralluftzufuhr
- (D) Primarni a sekundarni vzduch / Primary and secondary air / Primärluft und Sekundärluft
- (L) Volna plocha proskleni / Free glass area / Freie Glassichtfläche



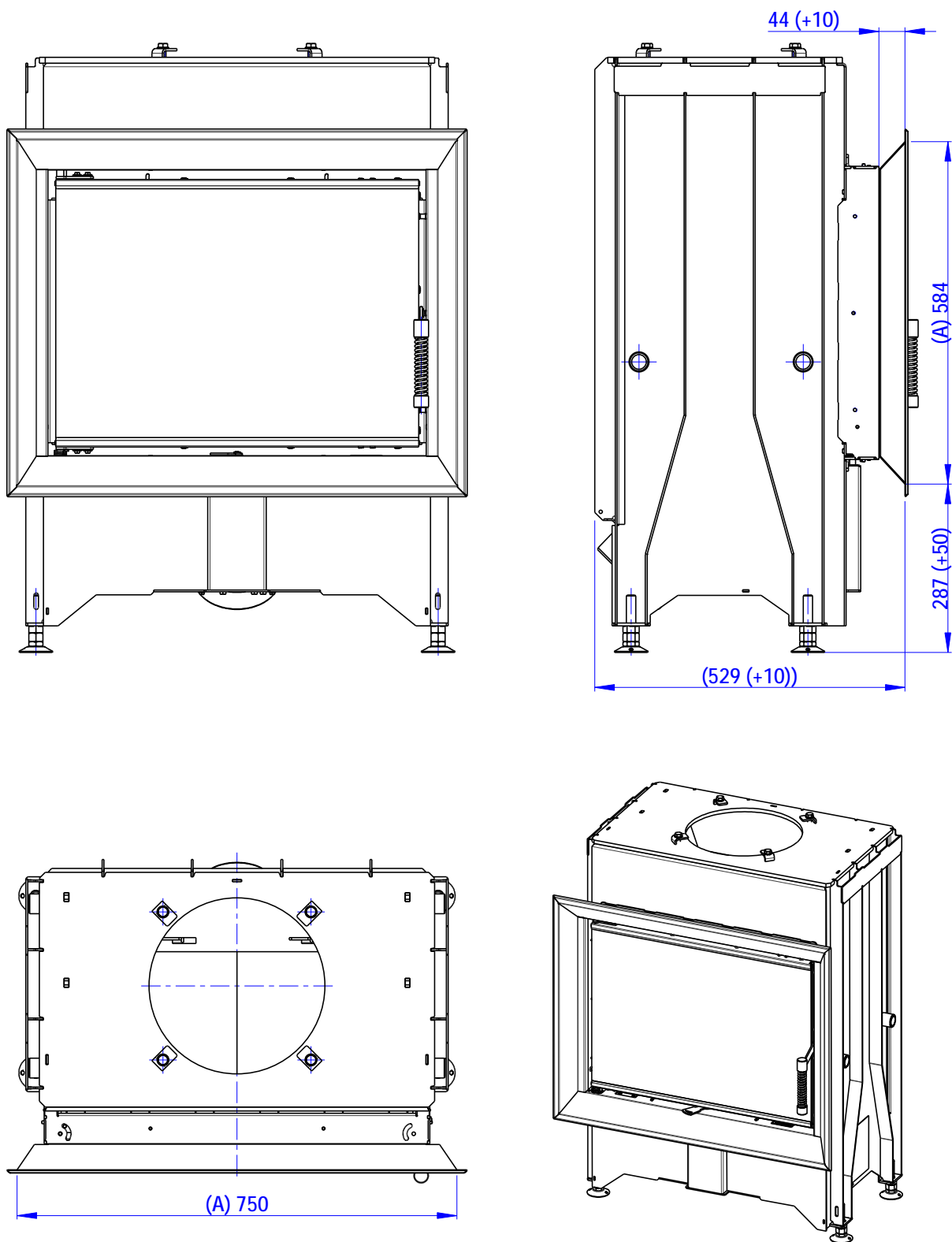

- (A) Zastavbovy rozmer / Baumaße / In-built dimension
- (B) Litinový odvod kouře / Cast iron spigot / Der gusseiserne Rauchabgang
- (C) Centralní privod vzduchu / Central air inlet / Zentralluftzufuhr
- (D) Primární a sekundární vzduch / Primary and secondary air / Primärluft und Sekundärluft
- (L) Volná plocha prosklení / Free glass area / Freie Glassichtfläche

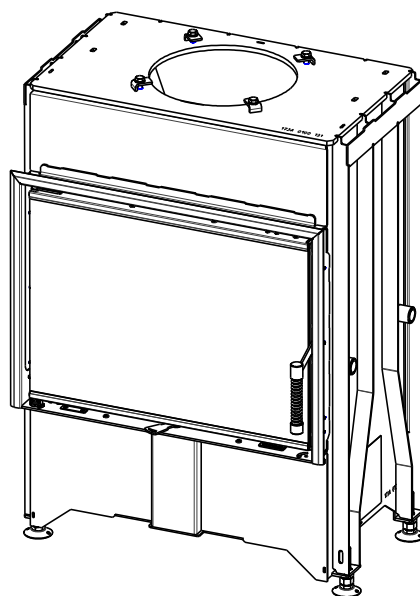
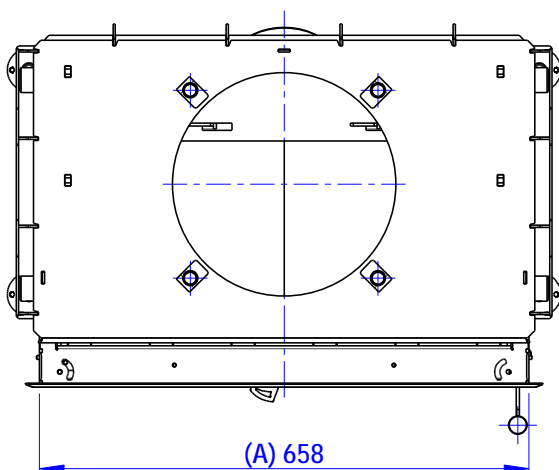
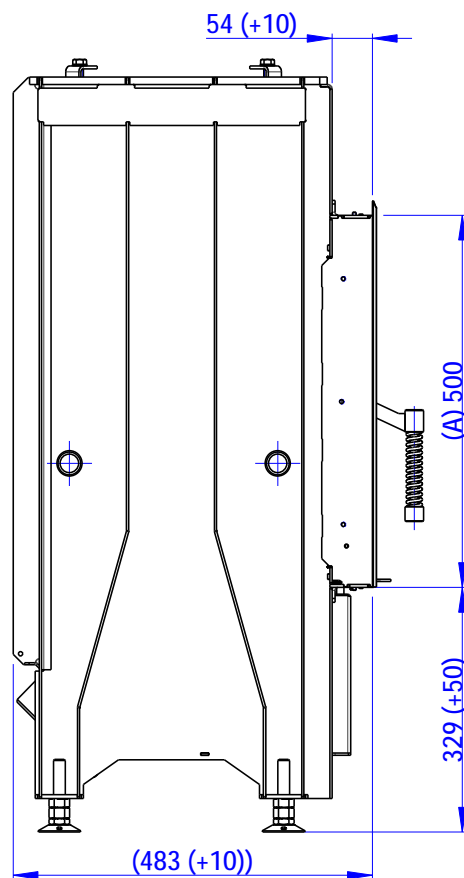
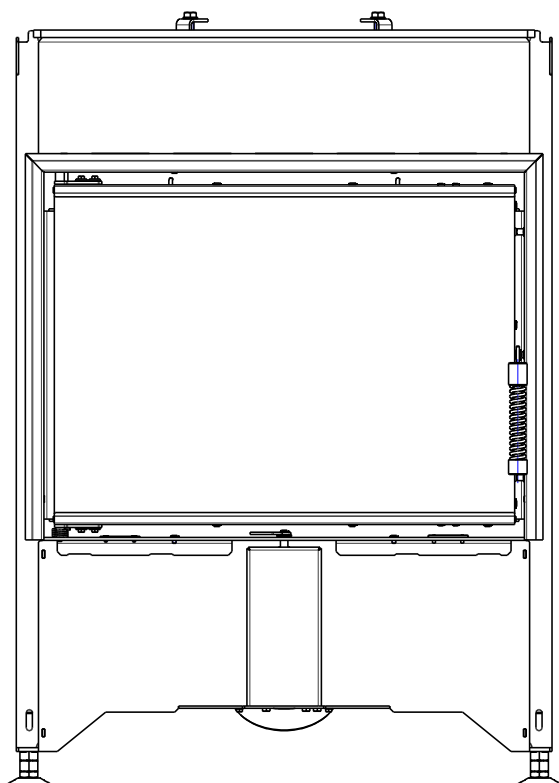

- (A) Zastavbovy rozmer / Baumaße / In-built dimension
- (B) Litinový odvod kouře / Cast iron spigot / Der gusseiserne Rauchabgang
- (C) Centralni privod vzduchu / Central air inlet / Zentralluftzufuhr
- (D) Primarni a sekundarni vzduch / Primary and secondary air / Primärluft und Sekundärluft
- (L) Volna plocha proskleni / Free glass area / Freie Glassichtfläche

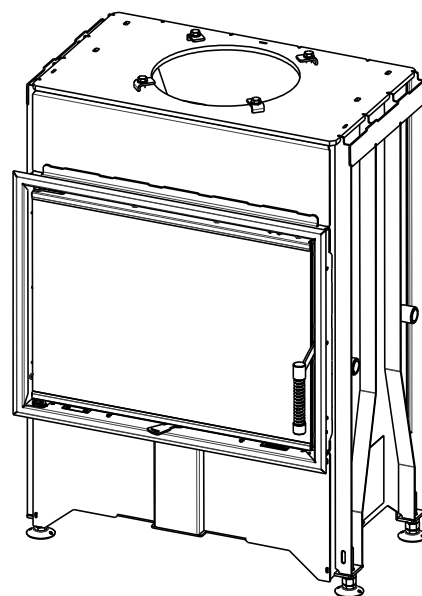
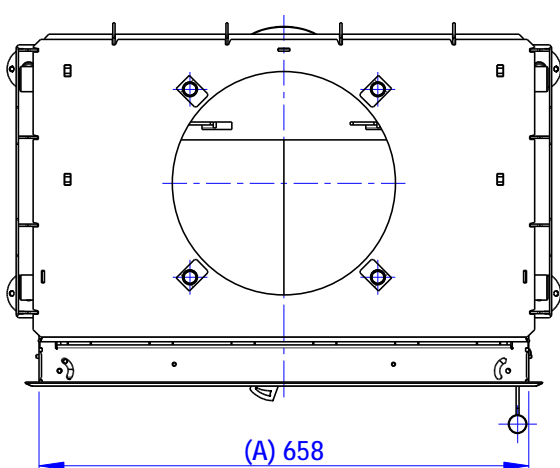
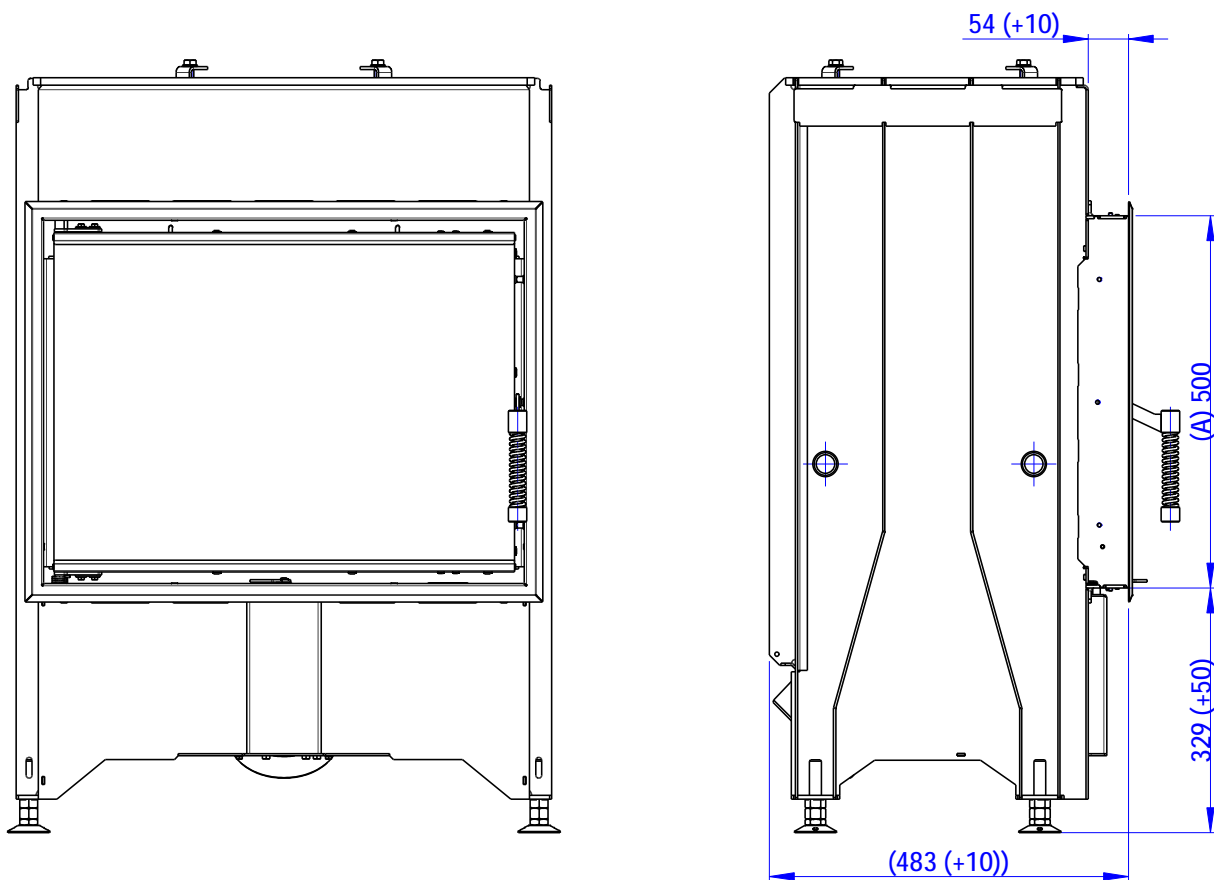

- (A) Zastavbovy rozmer / Baumaße / In-built dimension
- (B) Litinový odvod kouře / Cast iron spigot / Der gusseiserne Rauchabgang
- (C) Centralni privod vzduchu / Central air inlet / Zentralluftzufuhr
- (D) Primarni a sekundarni vzduch / Primary and secondary air / Primärluft und Sekundärluft
- (L) Volna plocha proskleni / Free glass area / Freie Glassichtfläche